

nonlinearcircuits

Product build & BOM

This module started out as an attempt to develop yet another chaos circuit by linking different nonlinear sub-circuits in series, from *Chaotic Oscillator Based on Delay Line - Milan Stork*. Then I noticed it was folding the waves at different offsets and kind of got diverted into developing a wavefolder.

It is similar in concept to other diode based wavefolders out there, but as this one uses two different nonlinear stages (twice each) rather than the same circuit 4 or 6 or 8 times, the folding is more complex, unbalanced and well, not very neat. What does this mean? It can be noisy 😊

There was a spare half of the LM13700 sitting there, so I added a VCA with fuzz, similar to the bottom circuit in the NLC VCAs module. The 3rd stage output of the wavefolder goes to the switching pin of the VCA input and the main input of the wavefolder goes to the switching pin of the VCA CV input. Using the offset pot gets it into ringmodulator territory, although this will also affect how the input signal will travel thru the wavefolding stages. This gives a 3rd output from the wavefolder (along with the main out and pulse out), which is even harsher than the main out. Otherwise, you can simply use it as a regular VCA or voltage controlled fuzz/distortion.



The circuit has a VCA at the front end with an OFFset pot and input feeding into the op amp gain stage. The OFFset CV input could be used as a 2nd input, bypassing the VCA, although the folds control is done by the VCA so this function will be absent. There are no capacitors for removing DC offset from the input signal, so the circuit can be used to process CVs if you wish.

From the VCA there are four nonlinear blocks in series, detailed below. The output of the 3rd stage is fed to the 2nd VCA input switching pin. The main input signal is fed to the 2nd VCA CV input switching pin. This means the VCA can be used to get a different folded output and this can get quite ropy with the Fuzz pot turned up.

The output of the 4th stage is the main out, this is also sent to a comparator which compare against the main input signal to get a 5V pulse, or rather a series of 5V pulses.

The OFFset pot gives both positive and negative offset, so it has minimal influence, or is at 0, at its midpoint. Generally best to leave it around there to start.

These screenshots from stork's paper show the nonlinear circuits and the effect they have on sinewaves:

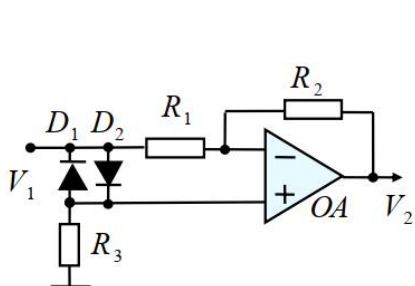

Fig. 3. Circuit diagram of the first nonlinear block N_1

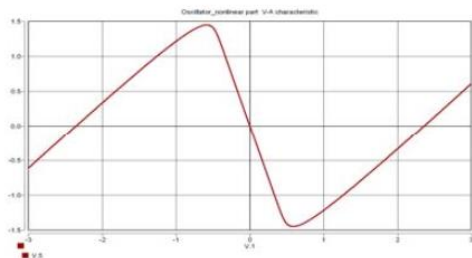

Fig. 4. Input-output voltage characteristic of the first nonlinear circuit N_1 ($R_1=100k$; $R_2=300k$; $R_3=100k$). V_1 -X axis, V_2 -Y axis

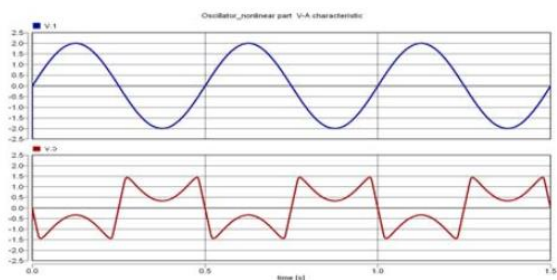

Fig. 5. Response of the N_1 circuit on sinusoidal signal. Top - input signal, bottom - response

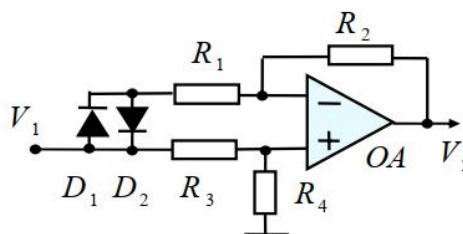

Fig. 6. Circuit diagram of the second nonlinear block N_2

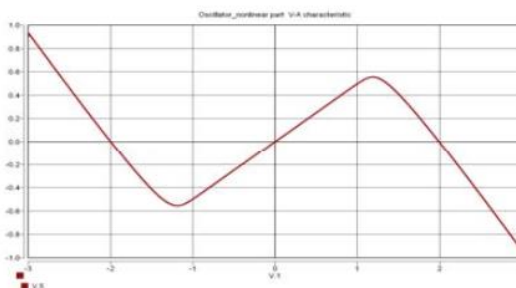

Fig. 7. Input-output voltage characteristic of the circuit N_2 for $R_1=R_3=R_4=100k$; $R_2=300k$. V_1 -X axis, V_2 -Y axis

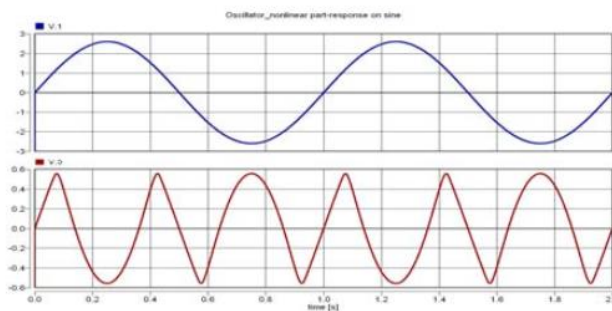

Fig. 8. Response of the N_2 circuit on sinusoidal signal. Top - input signal, bottom - response

BOM – The Tayda & Mouser part numbers are given as examples

VALUE	QUANTITY	DETAILS
100pF	4	0805 Tayda: A-3503
1nF	1	0805 Tayda: A-944
10nF	3	0805 Tayda: A-3507 see notes
47nF	1	0805 Tayda: A-3510
1uF	3	0805 25V or higher voltage rating
10uF	2	0805 25V or higher voltage rating Mouser: 963-TMK212BBJ106MG-T or similar
470R	4	0805
1k	6	0805
2k2	2	0805
10k	3	0805
12k	2	0805
30k	5	0805
47k	2	0805
100k	15	0805
220k	2	0805
300k	4	0805
470k	2	0805
1M	1	0805
1M2	3	0805
TL072 or TL082	3	Soic Tayda: A-1139, one is marked U9 for no reason whatsoever
TL074 or TL084	1	Soic Tayda: A-1140 or A-1137
LM13700M	1	soic Mouser Part No: 926-LM13700M/NOPB or 926-LM13700MX/NOPB
BC857	2	PNP sot23 Tayda: A-1345
LL4148	9	Tayda: A-1213
5V1 zener diodes	4	I use TZMC5V1-GS08
Eurorack 10 pin power connector	1	Tayda: A-198 cut to size
Schottky diodes	4	I use MBR0540 in a sod-123 package. Any with 30V+ and 0.25A+ ratings will do. dot on PCB indicates CATHODE (stripe on component).
3.5MM SOCKET Kobiconn style	8	Tayda: A-865 or Thonkiconn Jacks (PJ301M-12) from Thonk, Synthcube or Modular Addict
100k pots	6	Probably best to use T18 (or similar) splined/knurled shaft pots as the spacing is tight. Otherwise : Tayda: A-1848 or A-5513 or A-4729 or you could try with 200k or 50k pots, untested but should be ok. See notes

Additional notes:

1. The chips, resistors, caps are cheapest from Tayda. Schottky diodes, CMOS & 1uF, 10uF 25V 0805 caps from Mouser/E14/Farnell/etc.

2. Join the Nonlinearcircuits Builders Guild on FB: <https://www.facebook.com/groups/174583056349286/> and ask questions there if you have any. If you prefer not to FB then email is fine.

3. For some reason pots are somewhat scarce these days. It makes no sense to me, I order 1500 at a time from my regular supplier and get them in 3 weeks. If you want to order a minimum 500 pots @ \$0.30 each contact Rita at sales1hongyuan@163.com. Shipping is a bit pricey, but should still work out cheaper than buying from Tayda or elsewhere.

For knurled shaft you want

H09312NA B100K L15KQ-006

9mm single gang knurled shaft B100K rotary potentiometer ,no tab. hardware (nuts+washer) .shaft dia 6.0mm

For regular shaft (note these are 6mm, ask if you want 6.5mm), you want

RV9312NO-SB15A1.5-B104-060 no tab

9mm single gang B100K rotary potentiometer,no tab. hardware (nuts+washer) .shaft dia 6.0mm.

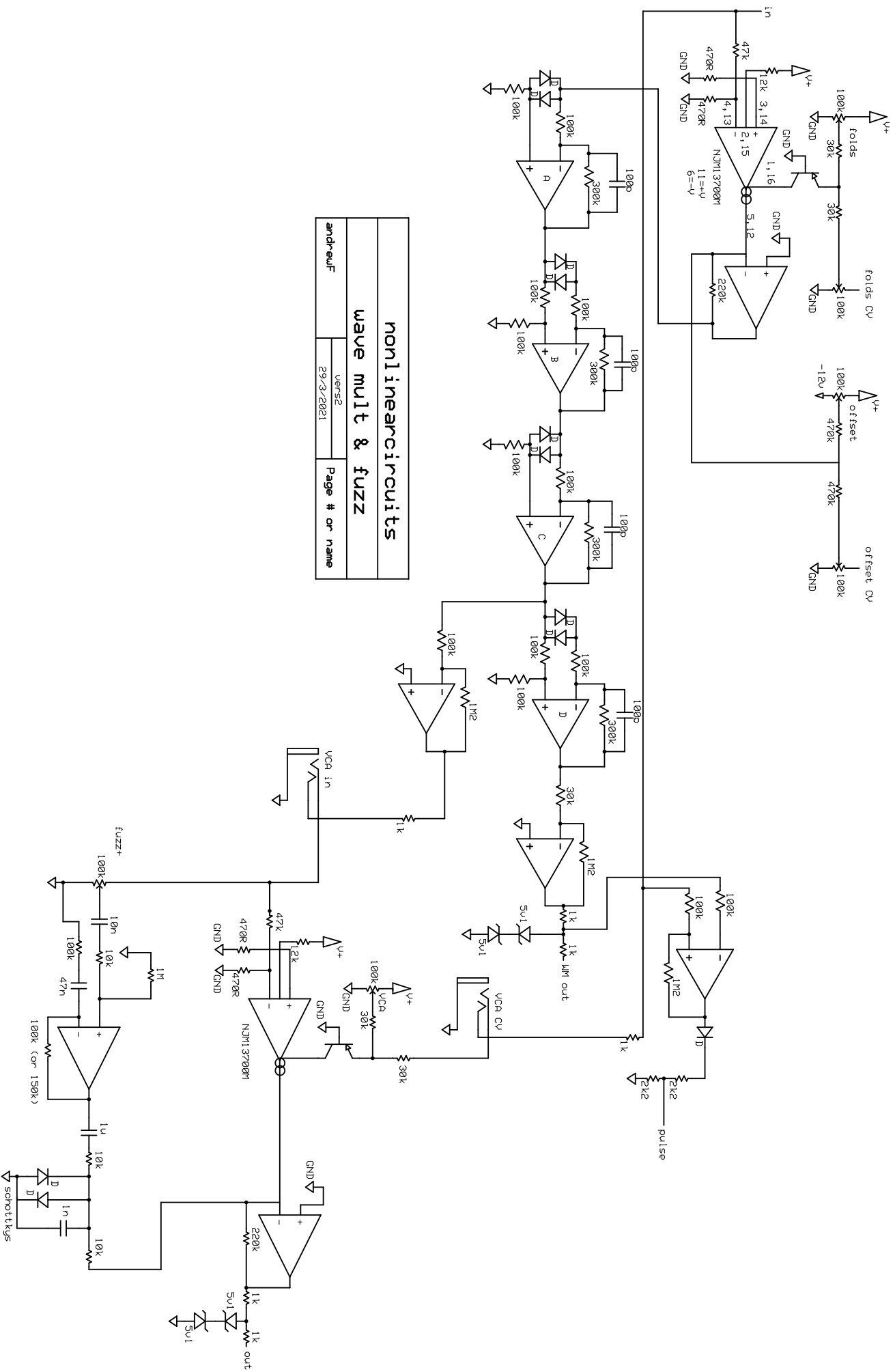

nonlinearcircuits	
wave mult & fuzz	
vers2	Page # or name
29/3/2021	
andrewf	

